



PRODUCTS CATALOG

ELECTRICAL ENCLOSURES & MODULAR CABINETS



20

exmweb.com

HINGED WINDOW COVER SUBMERSIBLE POLYESTER ENCLOSURES

The 5600 ESPLHW are suited for use indoors or outdoors where corrosion is a problem, to protect the enclosed equipment from water coming from any direction, dust, dirt and oil. The 5600 ESPLHW is made of a polyester and polycarbonate hybrid blend, aesthetically designed and produced exclusively by EXM. It is the material of choice for numerous indus-

trial applications. Its electrical, chemical and physical properties allow to be used in many environments and for a wide variety of applications. A high quality molded gasket ensures a complete NEMA 6P seal. The cover screws are made of stainless steel. The body of the 5600 ESPLHW enclosures incorporates mounting holes. **Enclosures can be com-**

pleted with an optional 14 GA galvanized inner panel, which can be mounted in the rear of the enclosure or on the cover. Cover screw inserts can be removed and replaced by quick release latches.

NEMA/EEMAC 6P / IP68

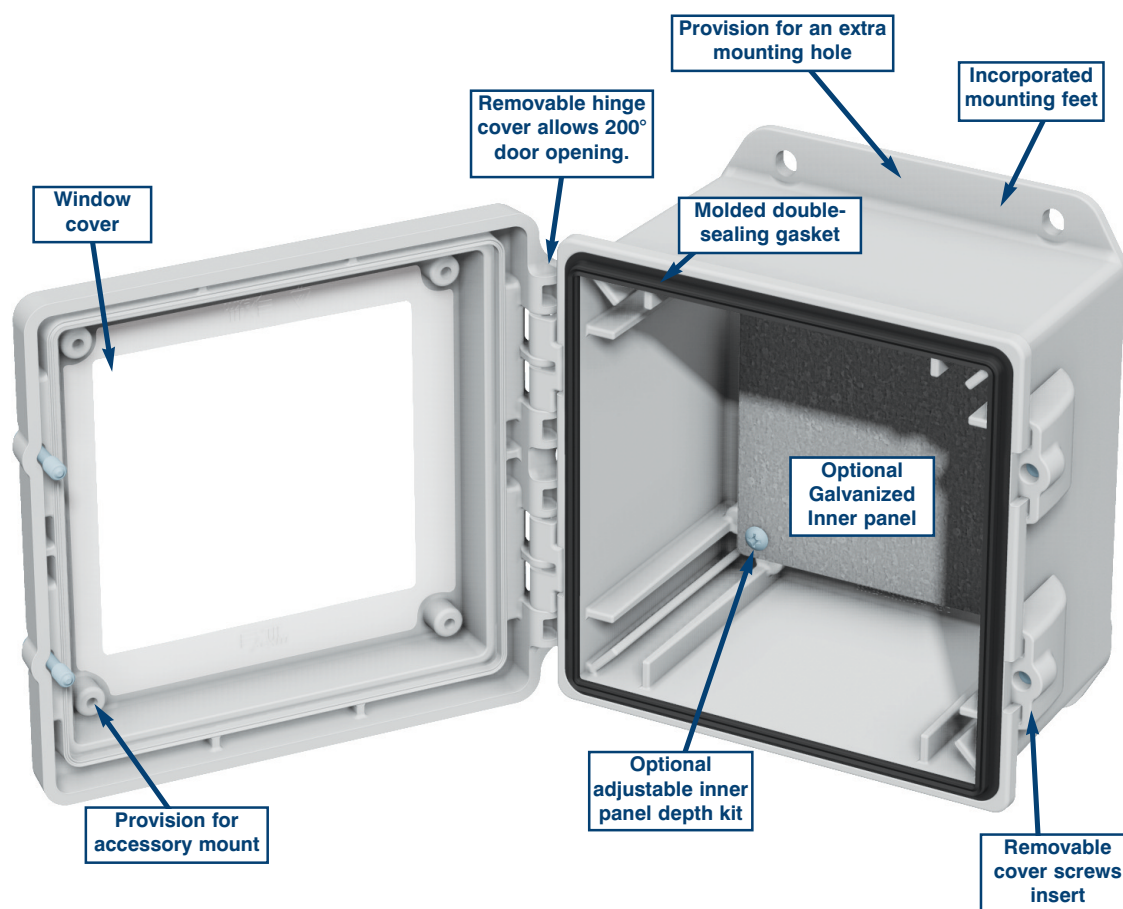

The 5600 ESPLHW
Available only from EXM

HINGED WINDOW COVER SUBMERSIBLE POLYESTER ENCLOSURES

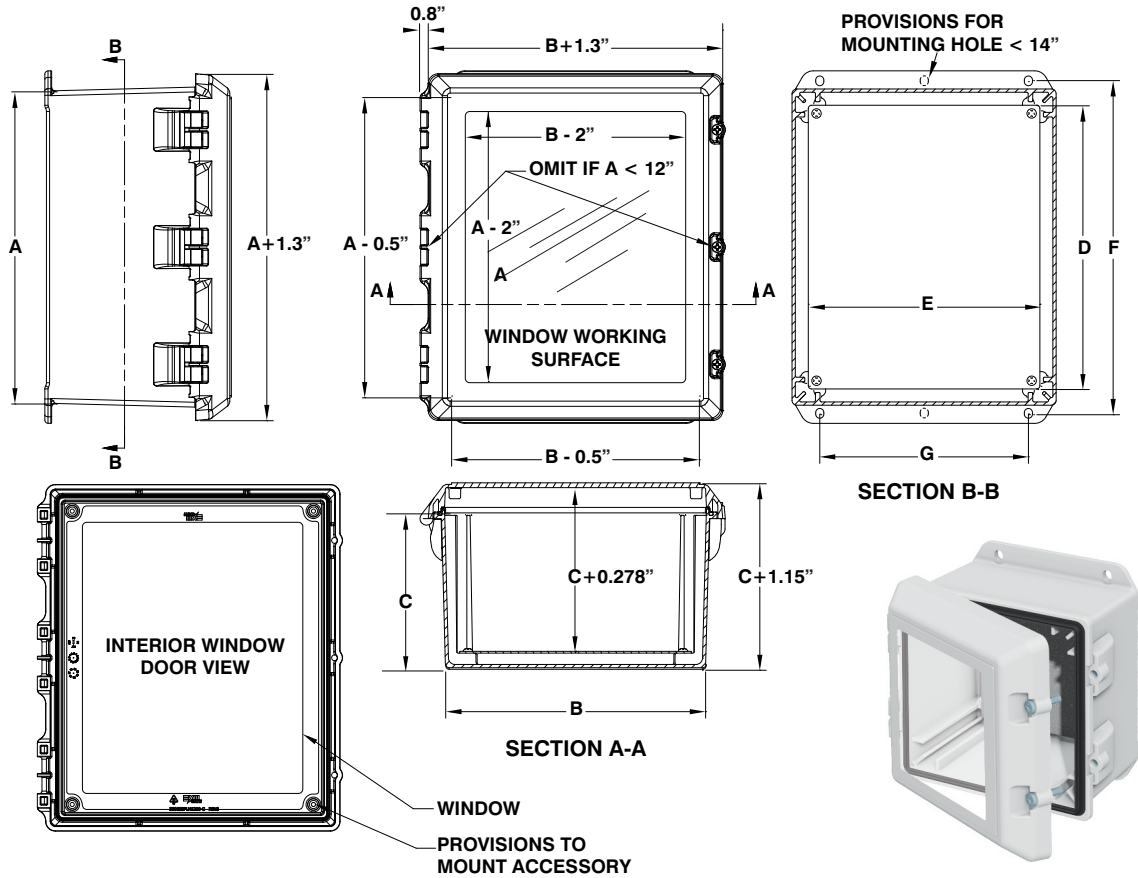

CATALOG NUMBER	DIMENSIONS								EQUIPMENT PANEL FULL	SHIP WGHT LBS.
	A	B	C	D	E	F	G			
5600 ESPLHW060404	6	4	4	4.88	2.88	6.75	2	880 SP0604G	1	
5600 ESPLHW060604	6	6	4	4.88	4.88	6.75	4	880 SP0606G	2	
5600 ESPLHW080604	8	6	4	6.88	4.88	8.75	4	880 SP0806G	2	
5600 ESPLHW080804	8	8	4	6.88	6.88	8.75	6	880 SP0808G	2	
5600 ESPLHW100804	10	8	4	8.88	6.88	10.75	6	880 SP1008G	3	
5600 ESPLHW101006	10	10	6	8.88	8.88	10.75	8	880 SP1010G	4	
5600 ESPLHW121005	12	10	5	10.88	8.88	12.75	8	880 SP1210G	7	
5600 ESPLHW121008	12	10	8	10.88	8.88	12.75	8	880 SP1210G	7	
5600 ESPLHW121206	12	12	6	10.88	10.88	12.75	10	880 SP1212G	7	
5600 ESPLHW141206	14	12	6	12.88	10.88	14.75	10	880 SP1412G	6	
5600 ESPLHW141208	14	12	8	12.88	10.88	14.75	10	880 SP1412G	6	
5600 ESPLHW161406	16	14	6	14.88	12.88	16.75	12	880 SP1412G	10	
5600 ESPLHW161408	16	14	8	14.88	12.88	16.75	12	880 SP1614G	10	
5600 ESPLHW161606	16	16	6	14.88	14.88	16.75	14	880 SP1616G	10	
5600 ESPLHW161610	16	16	10	14.88	14.88	16.75	14	880 SP1616G	12	
5600 ESPLHW201606	20	16	6	18.88	14.88	20.75	14	880 SP2016G	12	

CATALOG NUMBER	METRIC DIMENSIONS								EQUIPMENT PANEL FULL	SHIP WGHT LBS.
	A	B	C	D	E	F	G			
5600 ESPLHW060404	152	101	101	124	73	171	51	880 SP0604G	0.45	
5600 ESPLHW060604	152	152	101	124	73	171	102	880 SP0606G	0.91	
5600 ESPLHW080604	203	152	101	175	124	222	102	880 SP0806G	0.91	
5600 ESPLHW080804	203	203	101	175	175	222	152	880 SP0808G	0.91	
5600 ESPLHW100804	254	203	101	226	175	273	152	880 SP1008G	1.36	
5600 ESPLHW101006	254	254	152	226	226	273	203	880 SP1010G	1.81	
5600 ESPLHW121005	304	254	127	276	226	324	203	880 SP1210G	3.18	
5600 ESPLHW121008	304	254	203	276	226	324	203	880 SP1210G	3.18	
5600 ESPLHW121206	304	304	152	276	276	324	203	880 SP1212G	3.18	
5600 ESPLHW141206	356	304	152	327	276	375	254	880 SP1412G	2.72	
5600 ESPLHW141208	356	304	203	327	276	375	254	880 SP1412G	2.72	
5600 ESPLHW161406	406	356	152	378	327	425	305	880 SP1614G	4.54	
5600 ESPLHW161408	406	356	203	378	327	425	305	880 SP1614G	4.54	
5600 ESPLHW161606	406	406	152	378	378	425	356	880 SP1616G	4.54	
5600 ESPLHW161610	406	406	254	378	378	425	356	880 SP1616G	5.44	
5600 ESPLHW201606	508	406	152	480	378	527	356	880 SP2016G	5.44	